

## SAFETY RECALL CODE 0824 - SHOCK ABSORBER BRACKET

### Purpose

Buell Motorcycle Company has learned that certain 2002 Buell X1, M2, M2L, S3T motorcycles were manufactured between September 12, 2001 and November 14, 2001 with a rear shock front mount, Part Number K0407.01A1, which could be cracked. This condition could cause the shock mount to break, which may allow the suspension to drop unexpectedly. This sudden change in suspension height could cause a loss of control of the motorcycle without prior warning and could result in an accident. Buell Motorcycle Company has voluntarily declared this a defect related to motor vehicle safety (Campaign 0824) to allow us to formally recall all potentially affected motorcycles. The purpose of this bulletin is to announce the release of the proper shock absorber front mounting bracket for the affected motorcycles and to provide installation instructions.

### Dealer Action, Affected Vehicles

Buell Distribution Corporation has attached a complete list of all vehicles shipped to your dealership involved in this recall. To ensure the safety of all affected riders, it is your responsibility to perform the required service on all affected vehicles, even if the motorcycle was not purchased from your dealership.

If you are not sure that a safety recall has been completed on a particular Buell motorcycle, contact the recall information line at 1-800-448-1708. Recall information is also available on TALON and hd-net.com.

### IMPORTANT NOTE

*Because only registered owners, as shown on the attached list, will receive notification from Buell Distribution Corporation, we request that you contact any owners of vehicles still listed as unregistered. Advise them of the safety recall and make arrangements for them to come in for recall service. We also require that you provide us with their names, addresses and V.I.N.s as soon as possible. This will enable us to mail them an owner's letter as required by National Traffic and Motor Vehicle Safety Act, as amended.*

Initial shipment of recall kits, P/N 94004Y, will begin on or before January 9, 2002. All kits will be shipped direct from the Franklin Distribution Center, no charge, transportation paid. To order the remainder of kits that may be needed, please fill out the attached order form and send/fax it to the Warranty Department at (FAX) 414-343-8346.

Do not submit an order for additional kits until you have received your initial shipment and have determined your remaining requirements. Orders received before initial shipments are complete will be discarded.

Buell Distribution Corporation reserves the right to conduct wave shipments in lieu of processing orders and/or adjusting order quantities, depending on the availability of parts.

The shock absorber front mounting bracket kit, P/N 94004Y, consists of:

- (1) P/N K0407.01A1, New Front Shock Mount
- (1) P/N D1200.2CZ, Locknut, Nylon (shock mounting)
- (1) P/N DA0400.2FZ, Locknut, resevoir clamp

### IMPORTANT NOTE

**In the interest of preserving customer safety and satisfaction, always check for outstanding recalls whenever any motorcycle is brought into your dealership for either maintenance or service.**

ROUTING	SERVICE MANAGER	SALES MANAGER	PARTS MANAGER	LEAD TECHNICIAN	TECHNICIAN NO.1	TECHNICIAN NO. 2	TECHNICIAN NO. 3	TECHNICIAN NO. 4	RETURN THIS TO
INITIAL HERE									

# Removal

## NOTE

Perform the following procedures according to the guidelines given in the service manual for the model being serviced.

## All Models

1. Lift rear wheel off ground using REAR WHEEL SUPPORT STAND (Part No. B-41174). Secure front wheel of motorcycle in a suitable lift.

## WARNING

To protect against shock and accidental start-up of vehicle, disconnect the negative battery cable before proceeding. Inadequate safety precautions could result in death or serious injury.

2. Disconnect negative battery cable.
3. **X1 Models Only:** Remove chin fairing. See Section 2 of X1 Service Manual for procedure.

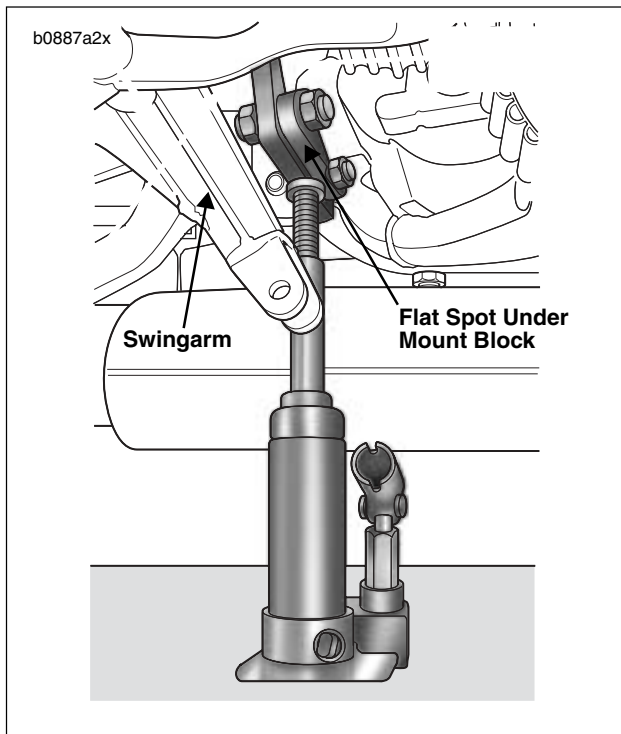

Figure 1. Jack Location on Mount Block (Shock Removed for Clarity)

4. See Figure 1. Place a suitable jack under the swing arm mount block and raise until crankcase is supported by jack for the purpose of unloading the shock absorber.
5. Remove button head screw that secures voltage regulator bracket to front shock mount. Leave bracket in place.

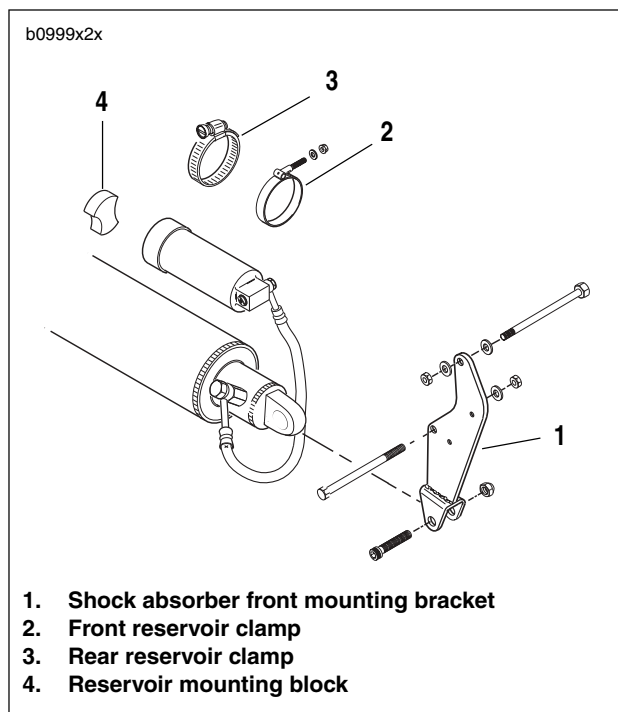

Figure 2. Front Shock Mount

6. Use a flex socket and extension to remove locknut and washer from front reservoir clamp. Discard locknut.
7. Loosen rear reservoir clamp. Slide reservoir out of clamp.
8. See Figure 2. Remove allen screw (metric) and locknut on front shock eye. Discard locknut.
9. Remove (2) crankcase bolts securing the front shock mounting bracket. DO NOT discard locknuts.
10. Remove front shock mounting bracket by pulling down and towards the front of the vehicle.

## Installation

1. See Figure 2. Loosely install **new** front shock mount to crankcase with original front shock mount bolts, washers and locknuts. Do not tighten fasteners at this point. NOTE: Top bolt goes in from the left side, bottom bolt goes in from right side. Bottom bolt does not use washer under bolt head.
2. **All Models:** Apply LOCTITE THREADLOCKER 243 (Blue) to threads of button head fastener. Fasten voltage regulator bracket to front shock mount with small button head fastener. Tighten fastener to 5-6 ft-lbs (7-8 Nm).
3. Tighten crankcase bolts and torque to 30-33 ft. lbs. (41-45 Nm).
4. **X1 Models Only:** Position chin fairing bracket in mounting position on front shock eye.
5. Install bolt through front shock eye and front shock mount and X1 chin fairing bracket (if applicable). Tighten bolt and **new** locknut to 40-45 ft. lbs. (54.2-61 Nm).
6. See Figure 2. Position front clamp over reservoir. Loosely install reservoir clamp to front shock mount with washer and **new** nylon locknut.
7. Install reservoir mount block between oil pump fitting and remote reservoir.
8. Tighten clamps around reservoir.

### CAUTION

**Be careful not to damage rebound label and ensure that label is positioned properly as to be seen from right side of vehicle.**

9. **X1 Models Only:** Install chin fairing. See Section 2 of X1 Service Manual for procedure.
10. Lower and remove jack from under swing arm mount block.
11. Connect negative battery cable. Tighten to 40 **in-lbs** (4.5 Nm).

## Credit Procedure

For each vehicle serviced, place a "C" in the letter box on the Buell Dealer Service Card. Send the properly completed dealer service cards to Buell Distribution Corporation, 3700 W. Juneau Ave., Milwaukee, WI 53208. Upon receipt and processing of your properly completed dealer service cards, you will be credited for 0.5 hours labor for M2, and S3T Models and 0.6 hours labor for X1 Models. All times include 0.1 hour administrative time. No credit will be issued for the kits as they were sent no charge, transportation paid.

## Disposition of Parts

**Destroy and discard all defective parts that have been removed from affected vehicles.**

